

Laney

Alliance USER MANUAL

**MODEL : VC50
 : VC100
 : VH100R**



IMPORTANT SAFETY INSTRUCTIONS

WARNING: When using electric products, basic cautions should always be followed, including the following.

1. Read all safety and operating instructions before using this product
2. All safety and operating instructions should be retained for future reference
3. Obey all cautions in the Operating instructions and on the back of the unit
4. All operating instructions should be followed
5. This product should not be used near water, i.e. a bathtub, sink, swimming pool, wet basement, etc.
6. This product should be located so that its position does not interfere with its proper ventilation. It should not be placed flat against a wall or placed in a built up enclosure that will impede the flow of cooling air.
7. This product should not be placed near a source of heat such as stove, radiator, or another heat producing amplifier.
8. Connect only to a power supply of the type marker on the unit adjacent to the power supply cord.
9. Never break off the ground pin on a power supply cord.
10. Power supply cords should always be handled carefully. Never walk or place equipment on power supply cords. Periodically check cords for cuts or signs of stress, especially at the plug and the point where the chord exits the unit.
11. The power supply cord should be unplugged when the unit is to be unused for long periods of time.
12. If this product is to be mounted in an equipment rack, rear support should be provided.
13. The user should allow easy access to any mains plug, mains coupler and mains switch used in conjunction with this unit thus making it readily operable.
14. Metal parts can be cleaned with a damp cloth. The vinyl covering used on some units can be cleaned with a damp cloth or ammonia based household cleaner if necessary. Disconnect the unit from the power supply before cleaning.
15. Care should be taken so that objects do not fall and liquids are not spilled into the unit through any ventilation holes or openings. On no account place drinks on the unit.
16. A qualified service technician should check the unit if:
 - The power cord has been damaged
 - Anything has fallen or spilled into the unit
 - The unit does not appear to operate correctly
 - The unit has been dropped or the enclosure damaged.
17. The user should not attempt to service the equipment. All service work is done by a qualified service technician.
18. Exposure to extremely high noise levels may cause a permanent hearing loss. Individuals vary considerably in susceptibility to noise induced hearing loss, but nearly everyone will lose some hearing if exposed to sufficiently intense noise for a sufficient time. The U.S. Government's Occupational Safety and Health Administration (OSHA) has specified the following permissible noise level exposure.

Duration Per Day In Hours	Sound Level dBA, slow response
8	90
6	92
4	95
3	97
2	100
1 ½	102
1	105
½	110
¼ or less	115

According to OSHA, any exposure in excess of the above permissible limits could result in some hearing loss. Ear plugs or protectors in the ear canals or over the ears must be worn when operating this amplification system in order to prevent a permanent hearing loss if exposure exceeds the limits set forth above. To ensure against potentially dangerous exposure to high sound pressure levels it is recommended that all persons exposed to equipment capable of producing high sound pressure levels such as this amplification system be protected by

SAVE THESE INSTRUCTIONS

Laney



Intended to alert the user to the presence of uninsulated “dangerous voltage” within the product’s enclosure that may be of sufficient to constitute a risk of electrical shock to persons



Intended to alert the user of the presence of important operating and maintenance (servicing) instructions in the literature accompanying the product

CAUTION: Risk of electrical shock - DO NOT OPEN

CAUTION: To reduce the risk of electrical shock, do not remove the cover. No user serviceable parts inside. Refer servicing to qualified service personnel.

WARNING: To prevent electrical shock or fire hazard, do not expose this appliance to rain or moisture. Before using this appliance please read the operating instructions for further warnings



Este simbolo tiene el proposito de alertar al usuario de la presencia de “(voltaje) peligroso” que no tiene aislamiento dentro de la caja del producto que puede tener una magnitud suficiente como para constituir riesgo de corrientazo



Este simbolo tiene el proposito de alertar al usuario de la presencia de instrucciones importantes sobre la operacion y mantenimiento en la literatura que viene con el producto

PRECAUCION: Riesgo de corrientazo - no abra

PRECAUCION: Para disminuir el riesgo de corrientazo, no abra la cubierta. No hay piezas adentro que el pueda reparar. Deje todo mantenimiento a los tecnicos calificados

ADVERTENCIA: Para evitar corrientazos o peligro de incendio, no deja expuesto a la lluvia o humedad este aparato Antes de usar este aparato, lea mas advertencias en la guia de operacion



Ce symbole est utilise pour indiquer a l'utilisateur de ce produit de tension non-isolee dangereuse pouvant etre d'intensite suffisante pour constituer un risque de choc electrique.



Ce symbole est utilise pour indiquer a l'utilisateur qu'il ou qu'elle trouvera d'importantes instructions sur l'utilisation et l'entretien (service) de l'appareil dans la litterature accompagnant le produit

ATTENTION: Risques de choc electrique - NE PAS OUVIRIR

ATTENTION: Afin de reduire le risque de choc electrique, ne pas enlever le couvercle. Il ne se trouve a l'interieur aucune piece pouvant etre reparee par l'utilisateur. Confier l'entretien a un personnel qualifie.

AVERTISSEMENT: Afin de prevenir les risques de decharge electrique ou de feu, n'exposez pas cet appareil a la pluie ou a l'humidite. Avant d'utiliser cet appareil, lisez les avertissements supplementaires situes dans le guide.



Dieses Symbol soll den Anwender vor unisolierten gefahrlichen Spannungen innerhalb des Gehauses warnen, die von Ausreichender Starke sind, um einen elektrischen Schlag verursachen zu konnen.



Dieses Symbol soll den Benutzer auf wichtige Instruktionen in der Bedienungsanleitung aufmerksam machen, die Handhabung und Wartung des Produkts betreffen.

VORSICHT: Risiko - Elektrischer Schlag! Nicht offen!

VORSICHT: Um das Risiko eines elektrischen Schlages zu vermeiden, nicht die Abdeckung entfernen. Es befinden sich keine Teile darin, die vom Anwender repariert werden Konnten. Reparaturen nur von qualifiziertem Fachpersonal durchfuhren lassen

ACHTUNG Um einen elektrischen Schlag oder Feuergefahr zu vermeiden, sollte dieses Gerat nicht dem Regen oder Feuchtigkeit ausgesetzt werden. Vor Inbetriebnahme unbedingt die Bedienungsanleitung lesen.

Laney



INTRODUCTION

Congratulations on your decision to purchase a **Laney** amplifier.

Laney products are designed with ease of operation as a primary objective, however to ensure you derive the best from your new amplifier, it is important you take time to read this user manual and to familiarise yourself with the control functions and facilities available

BEFORE SWITCHING ON

After unpacking your amplifier check that it is factory fitted with a three pin 'grounded' (or earthed) plug. Before plugging into the power supply ensure you are connecting to a grounded earth outlet.

If you should wish to change the factory fitted plug yourself, ensure that the wiring convention applicable to the country where the amplifier is to be used is strictly conformed to. As an example in the United Kingdom the cable colour code for connections are as follows.

EARTH OR GROUND - GREEN/YELLOW
NEUTRAL - BLUE
LIVE - BROWN

This manual has been written for easy access of information. The front and rear panels of each unit are graphically illustrated, with each control and feature numbered. For a description of the function of each control feature, simply check the number with the explanations adjacent to each panel.

Your **Laney** valve amplifier has undergone a thorough two stage, pre-delivery inspection, involving actual play testing, as well as valve burn in. Valves are the most important component in your **Laney** valve amp. However they are also the most fragile component. The glass envelope and valve filaments can easily be damaged in transit without any apparent signs of damage to the box, amp or valves. Valve damage is however quite simple to diagnose and even more simple to remedy. These procedures are explained later in this manual..

When you first receive your **Laney** valve amp, follow these simple procedures:

- (i) Ensure that the amplifier is set at the correct voltage for the country it is to be used in.
- (ii) Ensure that the speaker is connected to the appropriate socket.
- (iii) Connect your instrument with a high quality shielded instrument cable. Use of cheap cables will compromise the sound of your instrument and your amplifier.

If there is a problem with your **Laney** valve amplifier

DON'T



DO



PHONE YOUR DEALER!

Care of your **Laney** amplifier will prolong it's life.....and yours!. If you follow these guidelines your equipment will give you years of playing pleasure

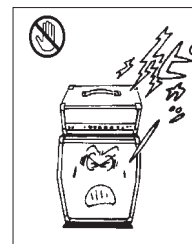
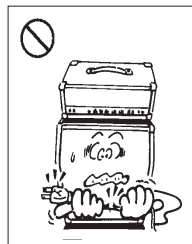
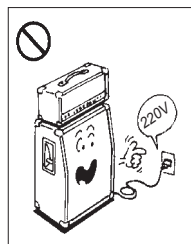
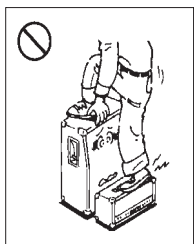

MODEL VC50/VC100 & VH100R

CLEAN

Both HI and LO inputs should be experimented with to obtain the sound you are looking for.

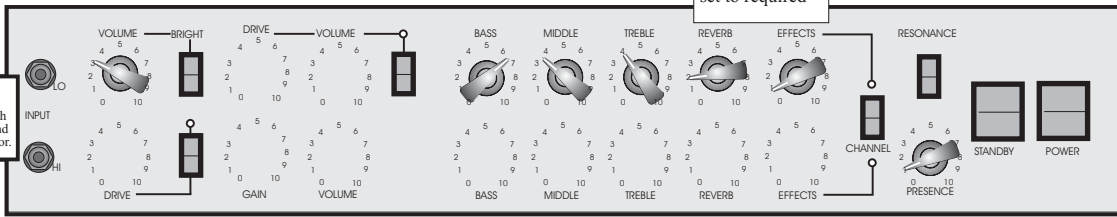

CLEAN CRUNCH

Both HI and LO inputs should be experimented with to obtain the sound you are looking for.

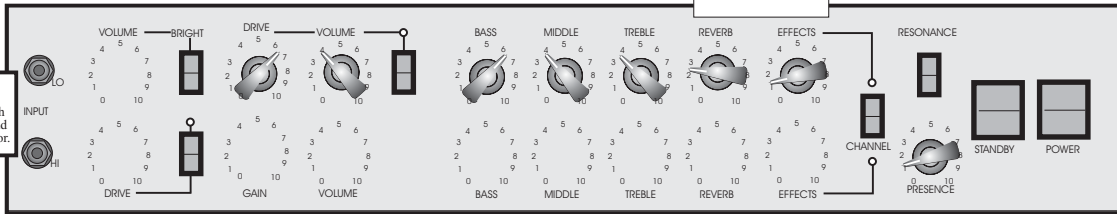

ROCK RHYTHM

Both HI and LO inputs should be experimented with to obtain the sound you are looking for.

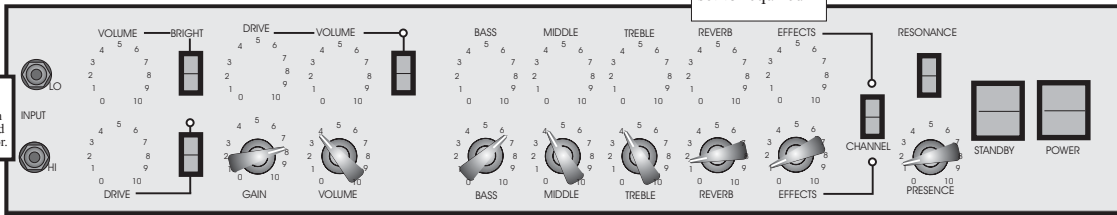

BLUES LEAD

Both HI and LO inputs should be experimented with to obtain the sound you are looking for.

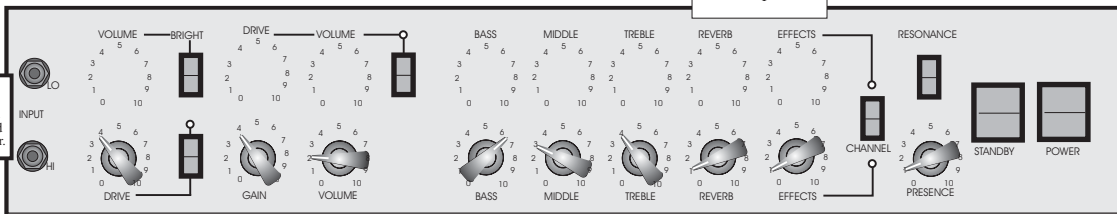

ROCK LEAD

Both HI and LO inputs should be experimented with to obtain the sound you are looking for.

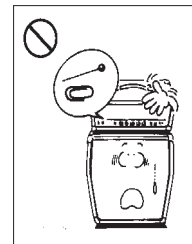
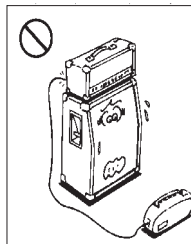
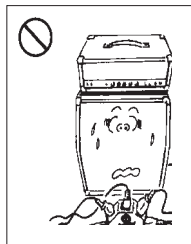
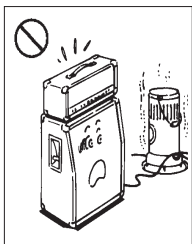
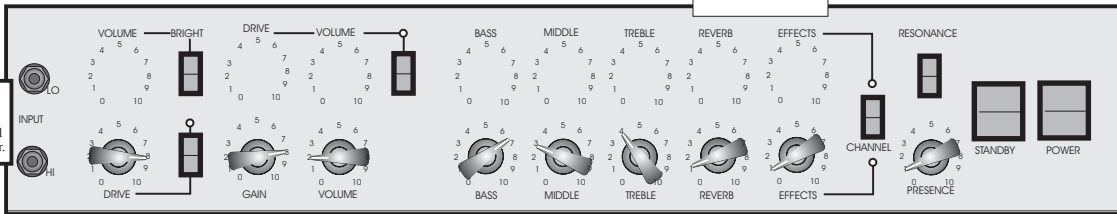

MODEL VC50/VC100/VH100R

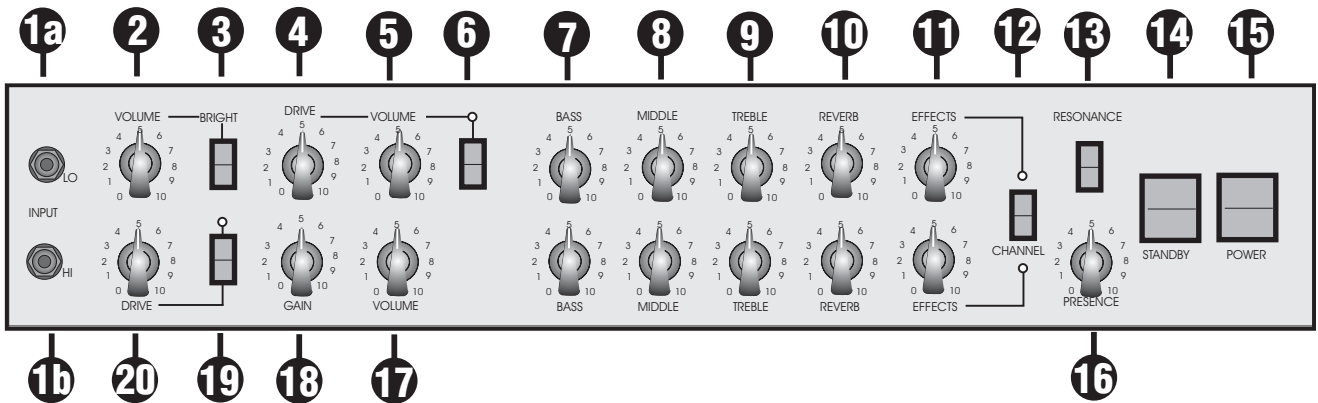

EXPLANATION OF TERMS

N.B. It should be noted that the layout of the control panel is reversed and inverted on the VH100R when compared to the layout diagrams

- 1a** **LO INPUT:** This input is attenuated down approximately 6dB from the high input. It is useful in obtaining output that is "tight" not "mushy" from high gain humbucker type pickups.
- 2** **VOLUME:** Adjusts the overall volume of the clean channel
- 3** **BRIGHT SWITCH:** Adds brightness and sparkle to the upper frequencies of the clean and clean drive channel
- 4** **DRIVE:** This pot controls the amount of 'Valve' drive applied to the circuit.
- 5** **VOLUME:** Sets the overall volume level of the clean channel drive sound.
- 6** **DRIVE SWITCH:** Engages the clean channel drive sound (Also footswitchable)
- 7** **BASS:** Controls the low frequency EQ in the pre amplifier.
- 8** **MIDDLE:** Controls the mid frequency EQ in the pre amplifier.
- 9** **TREBLE:** Controls the high frequency EQ in the pre amplifier
- 10** **REVERB:** Controls the level of reverb assigned to each channel
- 11** **EFFECTS:** Controls the signal level upon its return from an external processor and blends it to the desired level with the main signal.
- 12** **CHANNEL SWITCH:** Selects the required channel which is displayed by an illuminated indicator. The upper channel produces the clean tone and mild overdrive that is reminiscent of a sixties American valve combo. The lower channel produces the more substantial overdrive and distortion that is associated with British valve stacks.
- 13** **RESONANCE:** Adjusts the 'damping' control of the amplifier speaker enclosure, thereby controlling the 'tightness' of the bass response. This effect is very cabinet dependant so the switch should be adjusted to taste.
- 14** **STANDBY:** This switch enables/disengages the high voltage DC to the valves, switching the amplifier from a 'wait state' to an 'active state'. The AC voltage to the heaters is not effected by this switch so that an instant on of the amplifier is achieved when switching to an active state, so long as the POWER SWITCH has remained in the ON position. Always switch the amplifier to the 'STANDBY' before turning the main power switch off. This will prolong valve life

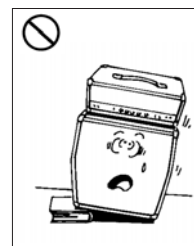
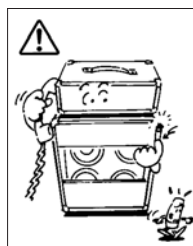

MODEL VC50/VC100/VH100R

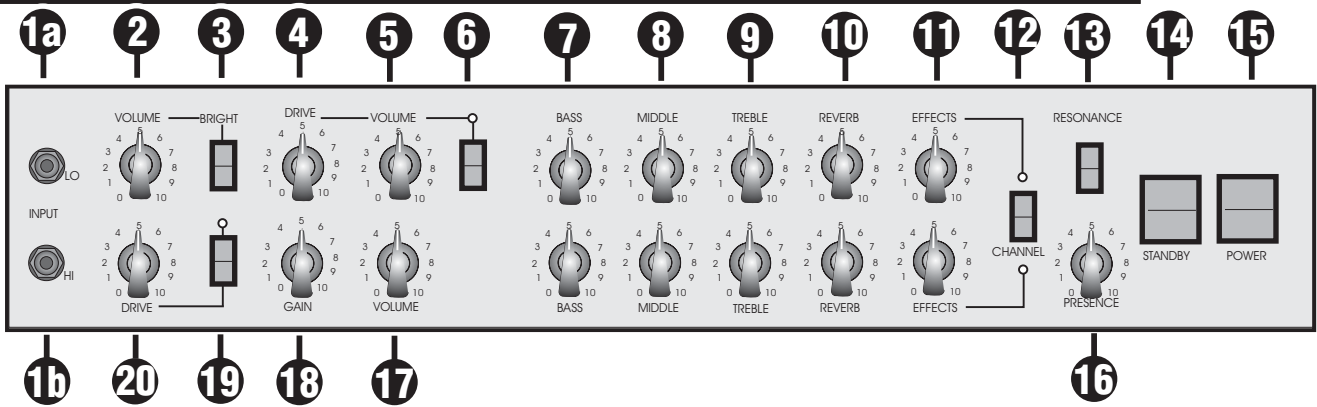

- 16 PRESENCE:** Controls the high frequency material in the power amplifier.
- 17 VOLUME:** Adjusts the overall volume of the overdrive channel
- 18 GAIN:** Adjusts the input level of the overdrive channel.
- 19 DRIVE SWITCH:** Allows activation of the overdrive section from the front panel.
- DRIVE:** Controls the amount of valve overdrive. The overdrive is applied to the circuit just prior to the gain control. The drive is engaged only when the drive switch (19) is on. The drive may be operated by the switch or remotely by the footswitch (FS4) connected on the rear panel.
- 20 DRIVE:** Controls the amount of valve overdrive. The overdrive is applied to the circuit just prior to the gain control. The drive is engaged only when the drive switch (19) is on. The drive may be operated by the switch or remotely by the footswitch (FS4) connected on the rear panel.
- 1b HI INPUT:** This input provides maximum gain from the instrument to the pre amp. It is extremely useful for guitars with single coiled or low gain humbucker type pickups. Use of high gain pickups in this input may drive the pre amp to severely, causing a "mushy" output.

VC50/VC100 BACK PANEL

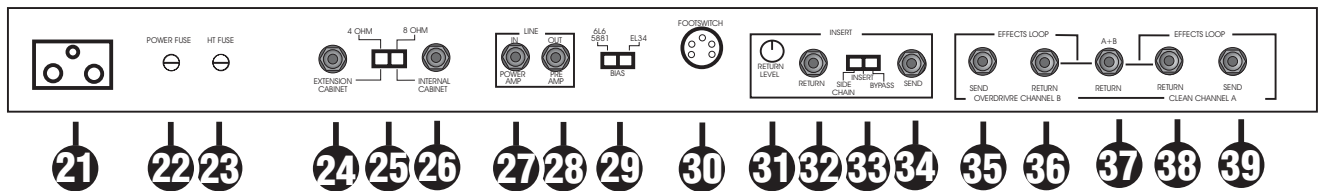

VH100R BACK PANEL

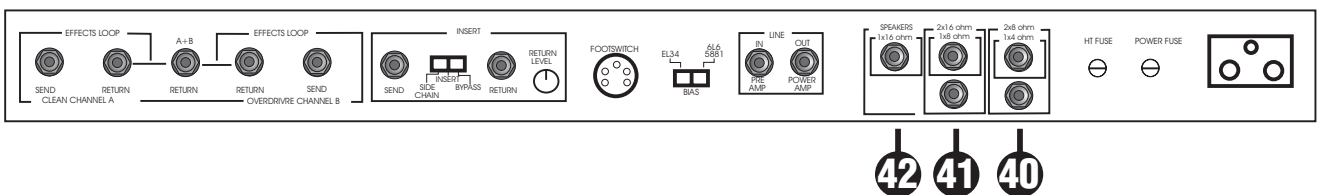

- 21 POWER CONNECTOR:** This is where the mains cable attaches.
- POWER FUSE:** This fuse protects the AC power of the overall amplifier. Use ONLY the correct size and rating of fuse as specified on the panel. If a fuse blows or fails and a replacement of the same size and rating is installed and it in turn blows, the amplifier has suffered a malfunction internally and needs immediate service from a qualified technician **DO NOT TRY USING A FUSE OF HIGHER RATING.**

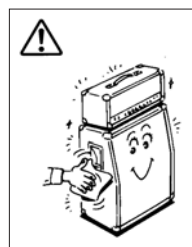
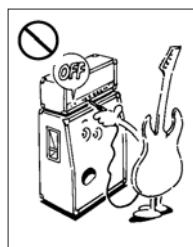

MODEL VC50/VC100/VH100R

VC50/VC100 REAR PANEL

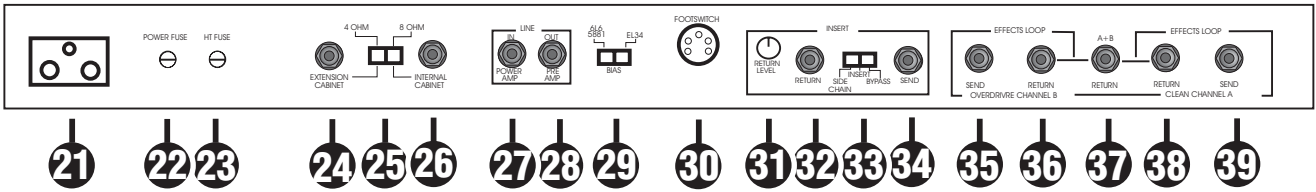

VH100R BACK PANEL

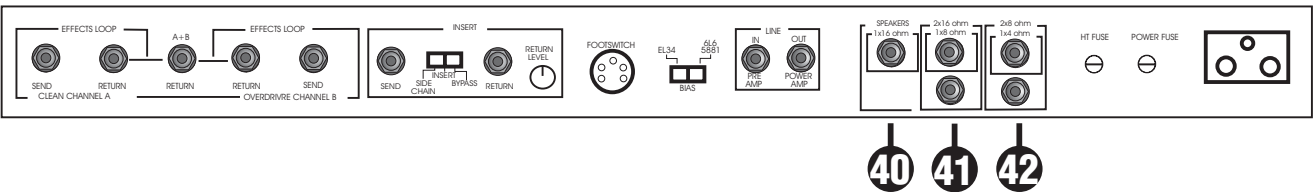

- 23 HT FUSE:** This fuse protects the DC power within the amplifier. Use only the correct size and rating fuse as specified on the panel. If a fuse blows or fails and a replacement of the same size and rating is installed and it in turn blows, the amplifier has suffered a malfunction, at this point check the output valves and replace faulty one if required. Should the valves not be the problem the amplifier should be checked out by a qualified technician. Do not try using a fuse of greater value. Using fuses that are too large in current rating may cause serious irreparable damage to the amplifier. Fuses are designed in to PROTECT, DO NOT take chances.
- 24 EXTENSION SPEAKER SOCKET:** Use to connect an 8ohm extension cabinet, model number GS212PE. When an extension cabinet is connected the resultant impedance will be 4 ohms and the speaker impedance switch should be set to 4 ohms. Mismatched impedance will reduce the amplifiers performance and in some cases may cause damage to your amplifier.
- 25 IMPEDANCE SELECTOR SWITCH:** This switches the internal impedance setting of the amplifier. When using with the 'on board' speaker set to 8 ohms. When an 8 ohm extension cabinet is also connected, set to 4 ohms.
- 26 INTERNAL SPEAKER SOCKET:** 1/4" output jack factory connected to the 'on-board' speaker. With no extension cabinet connected ensure that switch (5) is set to 8 ohms.
- 27 POWER AMP/LINE IN:** This socket is provided to allow a signal to be fed directly to the power amplifier from an effects unit or other pre amplifier. Connection at this point disconnects the internal pre-amplifier. Nominal level 0dBu.
- 28 POWER AMP/LINEOUT:** This socket provides an output from the pre-amplifier, post FX loop and may be used to drive other power amplifiers, FX units or mixing desks. Nominal level 0dBu.
- 29 BIAS SWITCH:** This is factory set to suit the valves fitted (5881). Should you wish to use EL34 valves the bias switch should be re-set accordingly.
- 30 FOOTSWITCH SOCKET:** This is a 5 pin 180 DIN socket for connection of the dedicated footswitch FS4 as supplied with the amplifier. FS4 is a four way switch for remote on both channels and reverb.
- 31 RETURN LEVEL:** This control adjusts the signal level returning from an external FX unit and allows the correct mix to be achieved. This may also be used to provide additional pre amp gain for both channels when the switch is deployed in the insert mode regardless of whether an effect unit is connected or not.
- 32 RETURN SOCKET:** This is provided to receive the output of an external FX unit being driven from the send socket (14)
- 33 FX MODE SWITCH:** For normal amplifier operation without FX this should be set to 'BYPASS' mode position. When the whole of the amplifier signal is required to be directed to an external effect, such as a Graphic Eq the switch should be set to 'INSERT' mode. The 'SIDE CHAIN' mode allows the connection of FX units such as delays, flangers etc, where a direct signal path is maintained to avoid the normal loss of dynamics through FX processors. When using this mode any FX unit should if possible be set to 'EFFECT ONLY' mode.
- 34 FX SEND SOCKET:** This provides an output from the pre-amplifier to drive effects units in conjunction with (12) & (13). Nominal level 0dBu.
- 35 FX LOOP SEND (OVERDRIVE CHANNEL):** This socket provides an output from the pre-amplifier for sending to an external FX processor. Processors fitted here operate in a 'side chain' mode and should be set for effect only operation if possible. Nominal level 0dBu



MODEL VC50/VC100/VH100R

VC50/VC100 REAR PANEL

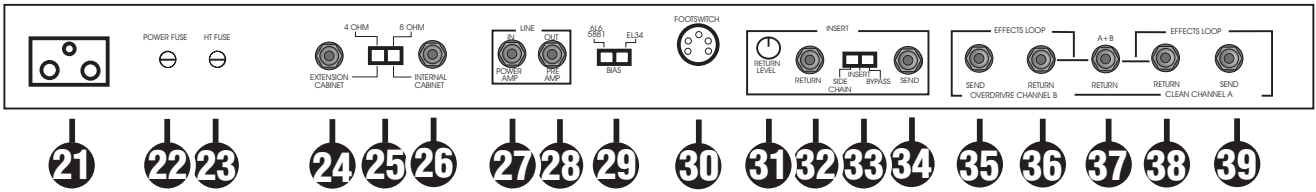

VH100R BACK PANEL

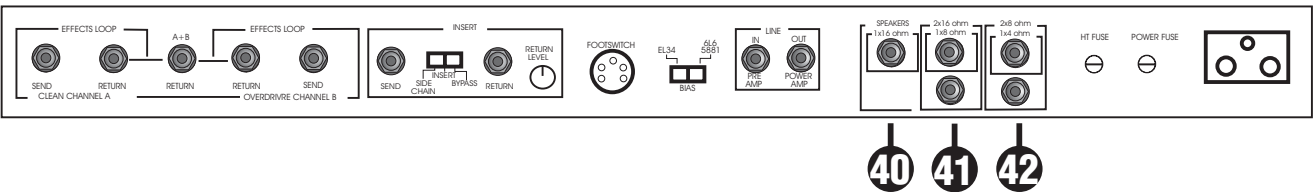

- 36** **FX LOOP RETURN (Overdrive Channel):** This socket is provided to accept the output of an external FX processor being driven from (15). The return level mix is controlled via the front panel effects level control.
- 37** **FX LOOP RETURN A+B:** This socket is provided for use when a single effects unit is to be used, on both channels, at different mix levels, via the front panel effect level controls. In this set up the effects units may be driven from either channel send sockets.
- 38** **FX LOOP RETURN (Clean Channel):** This socket is provided to accept the output of an external effects processor being driven from (19). The return level mix is controlled via the front panel effects control.
- 39** **FX LOOP SEND (Clean Channel):** This socket provides an output from the pre-amplifier for sending to an external FX processor. Processors connected here operate in the 'side chain' mode so should be set for effect only operation if possible. Nominal level 0dBu.
- 40** **SPEAKER OUTPUTS (VH100R):** A series of five 1/4" output jacks allows the user to correctly interface the output impedance of the amplifier to the selected speaker enclosures. In following the cabinet impedance information printed around the appropriate jack or jacks, correct operation and impedance matching is ensured.
- 41** Mismatched impedance will reduce the amplifiers performance and in some cases can cause irreparable damage.
- 42**

Ancillary Connection Examples

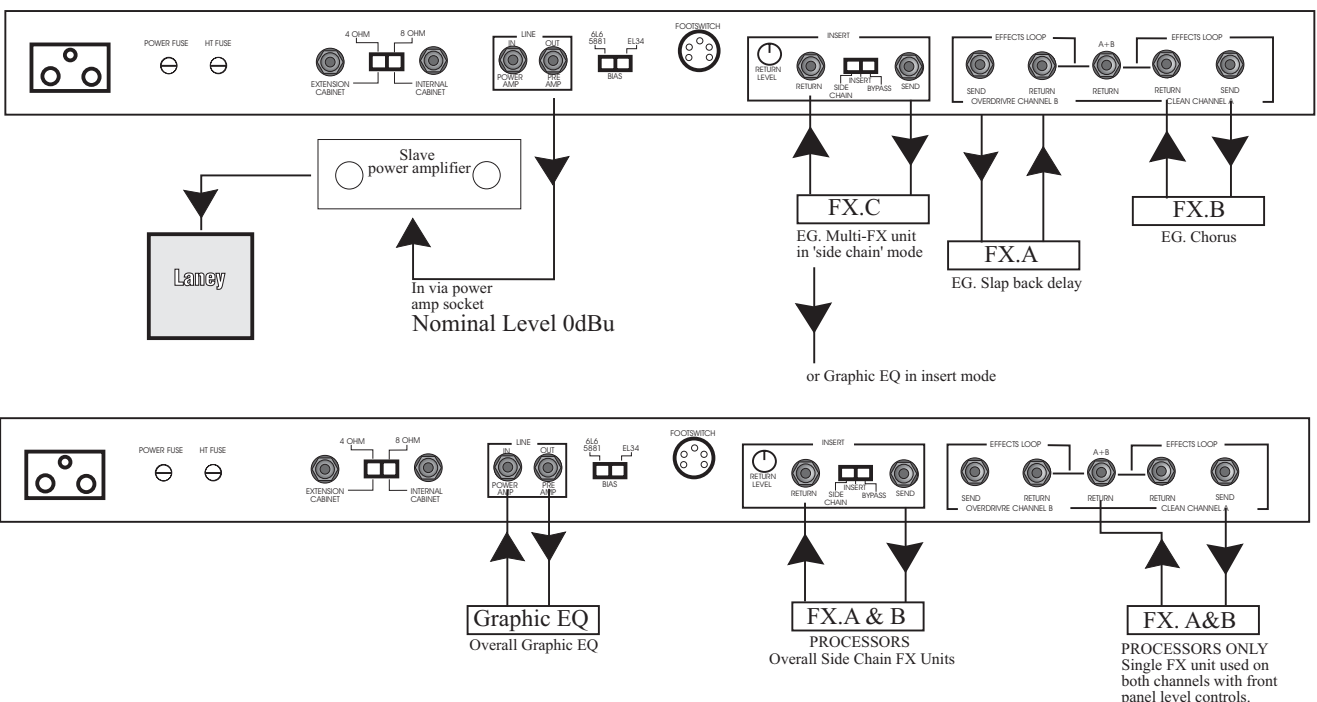



USEFUL HINTS AND TIPS

The following hints and tips are provided so that you can get the best performance out of your **Laney** valve amplifier. These are only guidelines and should be adapted for your own preferences:-

- 1: Valve amplifiers take a short time to 'warm up' to optimum operating temperature. To get optimum performance out of your amp allow the amplifier to 'warm up' for three mins. before you begin playing.
- 2: The position of an amplifier in a room has an effect upon the overall sound characteristics. If you wish to increase the bass response of your amplifier place the amplifier on the floor. If you wish to reduce the bass response of your amplifier place the amplifier on a stand.
- 3: Do not place you amplifier hard up against a wall as this will reduce the air circulating around the back of the unit and may result in overheating.
- 4: Connecting your guitar to either the 'HI' or 'LO' input has an effect on the sound, regardless of the guitar type/pickup configuration. The 'HI' socket provides more gain. The 'LO' socket provides a lower gain. You should experiment with both inputs to find the one which suits your guitar, style of playing and gives you the most tonally pleasing results.
- 5: When using the 'BRIGHT SWITCH' on the amplifier keep in mind that it has a greater audible effect the lower the amount of distortion produced by the preamplifier. At some distortion levels the 'BRIGHT SWITCH' may appear to have no effect at all.

VALVE REPLACEMENT AND TROUBLE SHOOTING

The valves in your new valve amplifier will eventually need replacing due to wear, this is normal with valve amps. In most instances you should be able to effect valve replacement yourself without incurring the costs of a service engineer. Following are some of the most likely symptoms of valve malfunction and a suggested method of correction.

Normally valve amps give optimum performance when fitted with matched sets of output valves as factory fitted to all **Laney** valve amps. NB: Damage will not occur by not fitting matched sets although the amplifiers performance may be impaired.

SYMPTOM 1

Amp connections have been performed correctly but power light fails to illuminate

SOLUTION 1

Check time delay POWER FUSE and replace if necessary:-
100-120 Volts 5 Amp time delay
220-240 Volts 2 Amp time delay

SYMPTOM 2

Power light illuminates, no sound out put

SOLUTION 2

Check secondary HT fuse and if blown replace with **1 amp time delay**

VALVE IDENTIFICATION

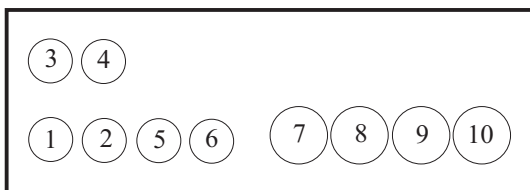

Pre Amplifier
input valves
6xECC83

Power Amplifier
output valves
4x5881 matched quartet

VALVE FUNCTIONS

- 1 First gain stage-Clean channel
- 2 2nd gain stage-Clean channel
- 3 First gain stage Drive channel
- 4 2nd gain stage Drive channel
- 5 3rd gain stage Drive channel
- 6 Power driver stage
- 7 & 8 2x5881 Output valves for VC50
- 7,8,9&10 4x5881 Output valves for VC100/VH100R.



SYMPTOM 3

Secondary HT fuse (1Amp time delay) blows repeatedly. This is a strong indication of a damaged output valve. The valve function chart shows the valve layout and the function each performs.

SOLUTION 3

Replace the secondary fuse and turn on the power WITH STANDBY ENGAGED. View the output valves. If one of the valves fails to light up, replace that valve. If both of the output valves are lit dimly, look directly at the output valves and disengage standby. If one of the valves flashes brightly or glows red hot in comparison to the adjacent valves, replace that particular valve. A simple way to verify that the valve is damaged is to switch the position of the suspect valve and follow the above procedure. If the valve exhibits the same symptoms in a different valve socket position, you can be certain that the valve is damaged.

If the output valve checks out OK, another cause of a blown secondary fuse is a damaged Driver pre amp valve No.6. Replace the Driver pre amp valve No.6 first and follow the above procedures. If the symptom persists, consult a qualified engineer, do not fit a higher rated fuse.

SYMPTOM 4

No pre amplifier boost on Drive channel

SOLUTION 4

Replace pre amplifier valves No. 1 & 2.

SYMPTOM 5

No clean channel, drive channel OK.

SOLUTION 5

Replace pre amp valve No. 3 & 4

SYMPTOM 6

Slow loss of power

SOLUTION 6

Check first for damaged output valves (glowing ,flashing or dead) by using the procedures described in symptom 3. Next check driver pre amp valve No.6.

All of these trouble shooting procedures can be performed quickly, without the aid of any sophisticated test gear. We suggest that you always maintain spare valves for emergency purposes. Keep your **Laney** free of dirt, dust and moisture to prevent performance failure Never subject your valve amp to environmental conditions that would not be comfortable to you!

Should other customer service be necessary, contact your authorised **Laney** dealer or call **Laney** service direct.

TECHNICAL SPECIFICATION

VC50

Maximum Power Consumption	200Watts
Supply Voltage (Factory Pre-set)	115/230 Volts
Supply Frequency	50/60Hz
Output Power	50 Watts
Input Impedance Hi	1 Meg Ohm
Input impedance Lo	470k Ohm
FX loop level (nominal)	0dB
FX send/return impedance	1k/100k Ohm
Speaker impedance	2x16 Ohm(8)
Extension speaker	8 Ohm
Speaker size	2x12"300mm
Speaker rating	80 Watts

VC100

Maximum Power Consumption	250Watts
Supply Voltage (Factory Pre-set)	115/230 Volts
Supply Frequency	50/60Hz
Output Power	100 Watts
Input Impedance Hi	1 Meg Ohm
Input Impedance Lo	470 K Ohm
FX loop level (nominal)	0dB
FX send/return impedance	1k/100k Ohm
Speaker impedance	2x16 Ohm (8)
Extension speaker	8 Ohm
Speaker size	2x12/300mm
Speaker rating	80 Watts

VH100R

Maximum Power Consumption	250 Watts	Supply Voltage (Factory Preset)	115/230 V
Supply Frequency	50/60 Hz	Output power	100 Watts
Input Impedance Hi	1 Meg	Input Impedance Lo	470 k Ohm
FX Loop/Line level (all nominal)	0dB	FX Send/Return impedance	1k/100 k Ohm

Laney
POWER TO THE MUSIC

www.laney.co.uk

In the interest of continued product development BLT Industries Ltd. Reserves the right to amend product specification without prior notification.