

Laney

BabelSwitch

MIDI Switcher and Signal Router

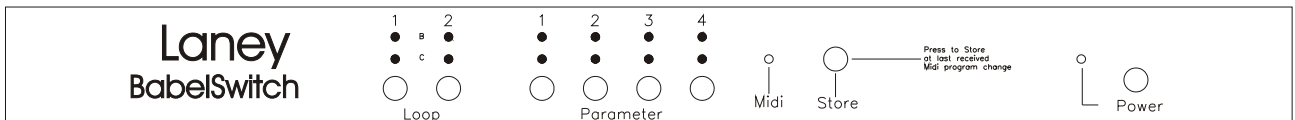

User Manual

THANK YOU

Thank you for purchasing the Laney BabelSwitch; we hope it provides greater flexibility to your MIDI system.

Please read this manual as it will demonstrate how to get the best from the BabelSwitch.

UNPACKING

After unpacking your BabelSwitch, please check carefully for any signs of damage that may have occurred whilst in-transit from the Laney factory to your dealer. In the unlikely event that there has been damage, please re-pack your unit in its original carton and consult your dealer.

We strongly advise you to store away your original transit carton since in the unlikely event that your unit should develop a fault, you will be able to return it to your dealer for rectification securely packed.

IMPORTANT SAFETY INFORMATION

The BabelSwitch requires an external 9V, 1A D.C. power supply: a suitable power supply is shipped with your BabelSwitch.

In the event of loss or damage to the power supply, replacements should be purchased from you Laney dealer. Failure to use the correct power supply could result in damage to your BabelSwitch.

The BabelSwitch should never be exposed to moisture or wetness since this would represent a possible shock or fire hazard and may cause expensive damage to your valuable possession.

The BabelSwitch contains no user serviceable parts. In the unlikely event of failure, please return to your dealer for repair.

Laney

BabelSwitch

MIDI Switcher and Signal Router

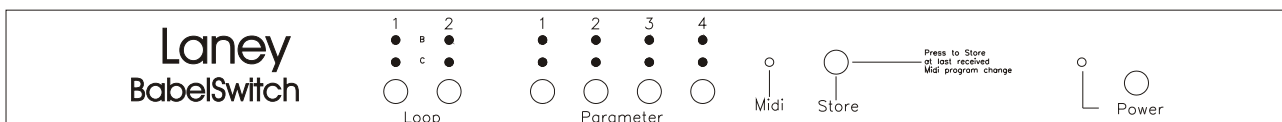

Contents

P1	Thank You
P 2	Contents
P 3	Declaration of Conformity
P 4	What it does ?
P 5	BabelSwitch Switch Functions
P 6	Application - Simple Midi Switching
P 7	Application - Simple Switching + FX switching
P 8	Application - Simple Switching + FX switching + Loop Switching
P 9	Application - Midi Boost
P 10	Application - Multiple Amp Set-up
P 11	Application - Typical set up
Appendix 1	Switching Specification + Multiple Amp Grounding
Appendix 2	Glossary
Appendix 3	Trouble switching
Appendix 4	Midi Implementation

In the interests of continuing product development
BLT Industries Ltd reserves the right to change specification
without prior notice. No part of this manual can be reproduced, copied
or transmitted by any means without the express written permission of BLT Industries Ltd.

DECLARATION OF CONFORMITY

Certificate No.: 1080

Ref: The Electromagnetic Compatibility Regulations (S.I. 1992/2372)
The Electrical Equipment Safety Regulations (S.I. 1994/3260)

Date of issue: 17/04/98

Manufacturer: BLT Industries Ltd.,
Newlyn Road,
Cradley Heath,
Warley,
West Midlands,
B64 6BE
United Kingdom

Tel: (+44).(0)1384 633903
Fax:(+44).(0) 1384 639186

Model No. of Apparatus: BabelSwitch

Description of Apparatus Midswitching device
Insulation and Earthing to Class 2.

Applicable Standards: EN55013: 1990
EN55020: 1988
EN60065: IEC65/5 (1985)
FCC Requirements for Class B computing equipment

Certificate: The apparatus to which this Declaration of Conformity relates , the particulars of which are detailed above , conforms with the protection requirements of:

Council Directive 89/336/EEC relating to Electromagnetic Compatibility .
Council Directive 73/23/EEC relating to Low Voltage Directive .

BabelSwitch - What It Does

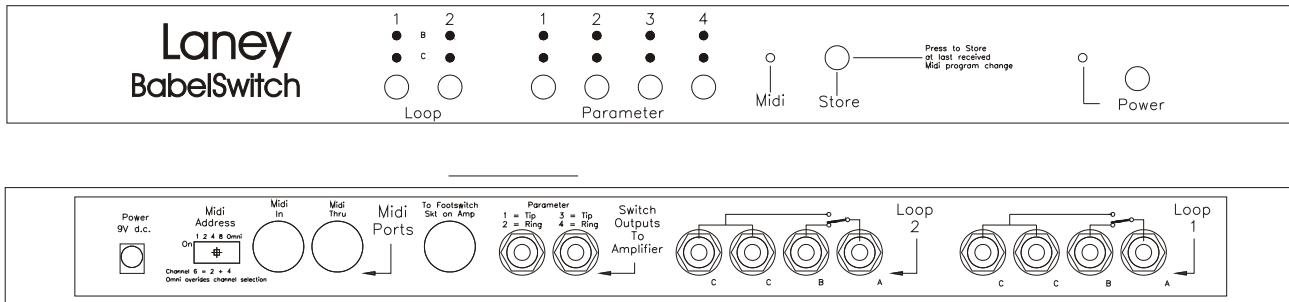

BabelSwitch Operation

The BabelSwitch provides midiswitching capability to all Laney amplifiers. It simply plugs into the footswitch socket, provision is made for the BabelSwitch to mimic any of the range of Laney footswitches.

The BabelSwitch decodes midi program change instruction and provides the following.

1. Midi switching of footswitch function, allowing you to store your amp settings with your favourite Midi Patches.
2. Switch FX in and out of your amplifiers FX loops via Midi
3. Midi controlled routing of preamp signals in multi-amplifier set-ups
4. Midi controlled routing of guitar level signals

All this information can be recalled via midi program change instructions

Operation

1. Connect your amp/midi setup.
2. Select a new patch on your midi controller/pedal board.
3. Select the amp switch setting via the BabelSwitch front panel controls.
4. Press STORE on the BabelSwitch.

Your amplifier switch setting will be recalled the next time that patch is called.

BabelSwitch Switch Functions

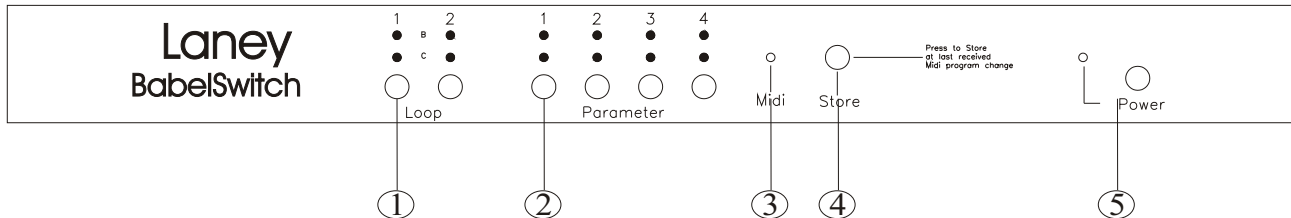

- ① Allows the connection of jack Socket A to either jack Socket B or jack Sockets C (located on the rear panel)..LED indication shows which jack socket A is connected to.
- ② Switches the status of the amp connected to the 5 pin footswitch skt or the amp/s connected to the 2 stereo jacks
- ③ Indicates the BabelSwitch is receiving midi data.
- ④ Stores the current switch status of the Babelswitch at the last received midi program change if depressed for 1 second - i.e. The last received patch change.
- ⑤ Switches power to the BabelSwitch.
Disconnect the d.c. Power from the BabelSwitch if it is not in use

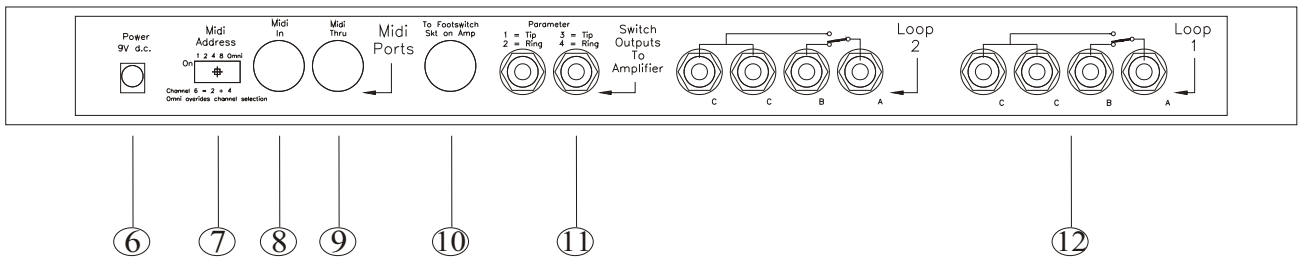

- ⑥ Connect power to the BabelSwitch here - 9V 1A d.c. Via a socket for 2.1mm plug
- ⑦ Selects which midi channel the BabelSwitch responds to (0-15)If the BabelSwitch is required to respond on all Midi channels select Omni - this overrides any channel selection.
- ⑧ BabelSwitch Midi Input - connect the midi out of your midi controller here eg your pedal board. A thru connection is made for phantom powered devices using 7 pin Din leads
- ⑨ BabelSwitch Midi thru - connect other midi devices here.
A thru connection is provided for devices using phantom power on 7 pin DIN cable
- ⑩ Connect a 5 pin din lead to the FS4 / FS5 socket on combo/head.
This will allow you to switch your combo/head via the front panel controls on the Babelswitch
- ⑪ These sockets allow remote control of combo's/amplifiers with FS1/FS2 footswitches.
Simply connect a stereo/mono jack lead (as required) from one of these sockets to the footswitch socket of your amplifier.
- ⑫ Switching jacks - The tip of jack socket A can be connected to either the tip of jack socket labeled B or the tip of jack sockets labeled C. See application notes for more information

BabelSwitch Application Notes

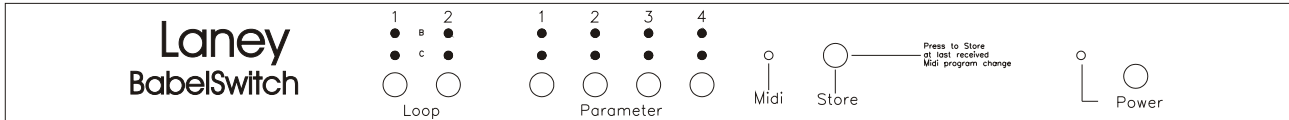

The BabelSwitch provides

- 1) 4 channel switching outputs on a 5 pin Din socket and 2 stereo jacks
- 2) 2 channels of switching jacks.

The status of all the loop/parameter switches can be stored for recall via midi program change instructions. Midi program changes are generated by midi foot pedal when a patch is changed. This facility allows you to effectively store the switch setting of a combo/head for recall via midi.

BabelSwitch Application One - Simple Midi switching

- 1) Connect the Midi out of your pedal board board to the Midi in on your Babel Switch
- 2) Connect the 5 pin Din switch output to the FS4/FS5 socket on you combo/head.
- 3) Connect power to all of the above.
- 4) Select the required patch on your pedal board
- 5) Select the desired switch status of your combo/head using the BabelSwitch parameter switches.
- 6) Press STORE when you are happy with the settings.
- 7) The next time you recall that patch your combo/head will return to that stored setting.

Changing your sound now only requires the enabling of a patch on a pedal board/Midicontroller. No need to reconfigure the pedal board then reconfigure amp.

The BabelSwitch retains all stored settings after power down for later use.

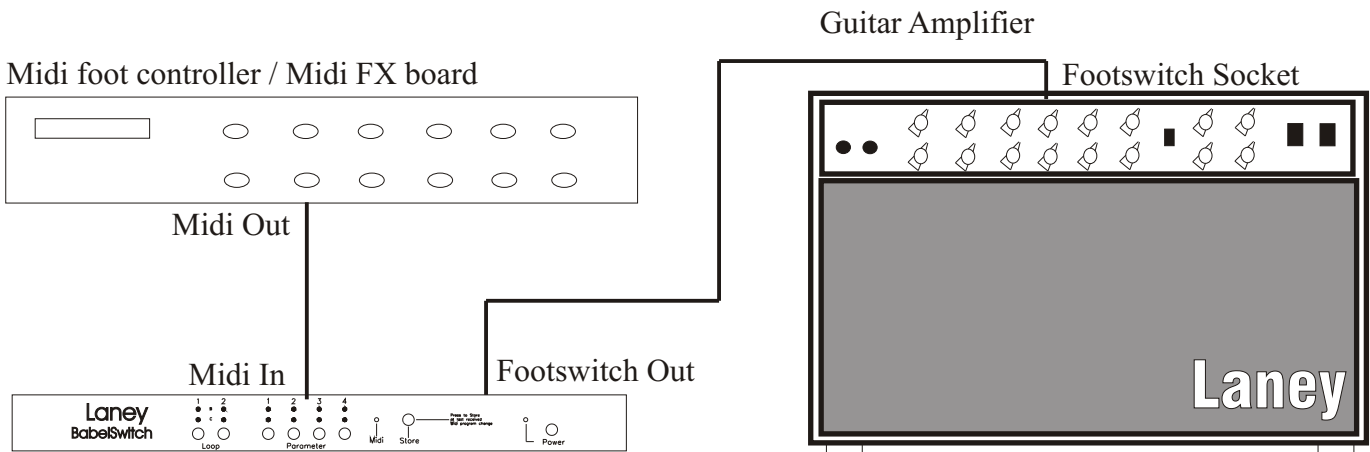

Notes :

- 1) Ensure the amplifier / head front panel switches are in a state which allows remote control. Refer to your amplifiers manual for information.

BabelSwitch Application Notes

BabelSwitch Application Two - Simple Midi switching FX Switching

The next step in building our midi set up is incorporating an external processor into the midi chain. This could be in the effects loop of the amplifier or in the input line of the amplifier.

Doing this now allows us to store at the touch of a button :-

- 1) Amplifier Switch Status
- 2) Midi pedal board / FX board status
- 3) Multiple effects processor status

To get the best from this set up you will have to map FX within a processor to program change /patches generated by the midi controller/pedalboard. Refer to your fx processors manual to achieve this

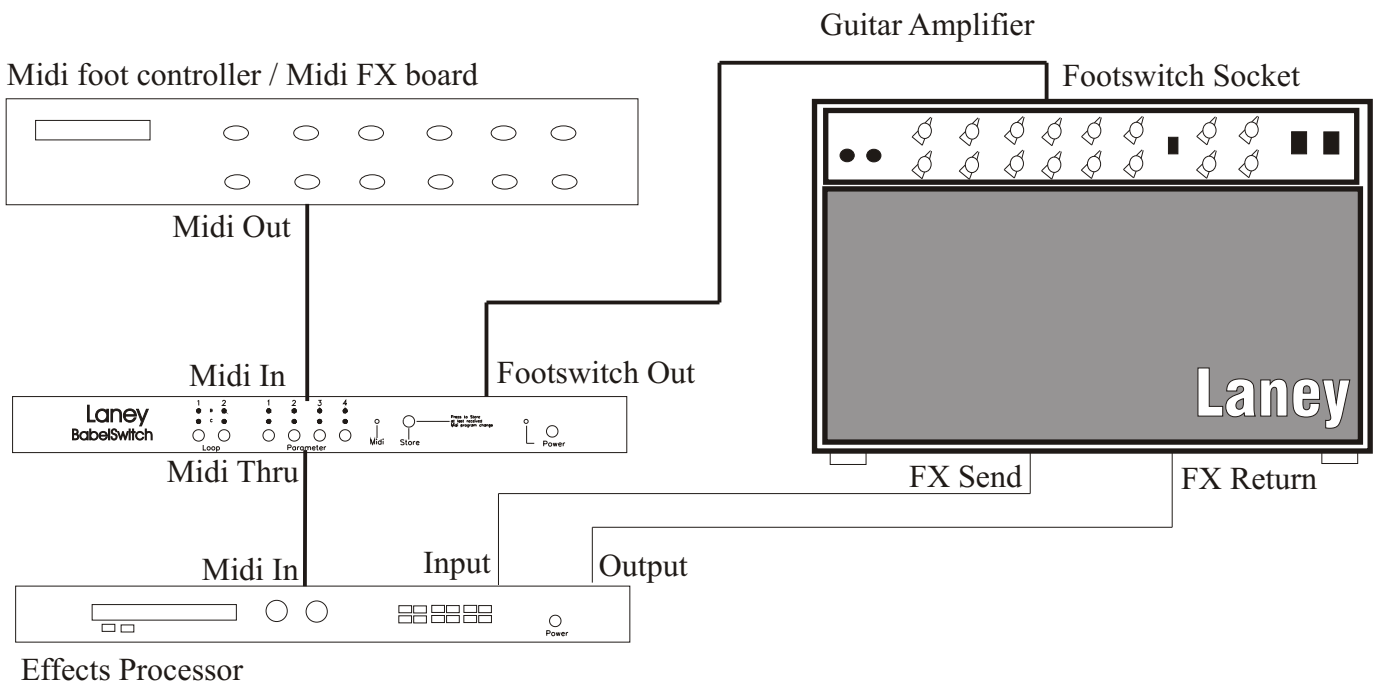

Notes :-

- 1) Ensure the amplifier front panel switches are in a state which allows remote control.
 - 2) We recommend that the BabelSwitch is connected directly after the Midi controller in a midi system as FX processors generate program change instructions. (It is preferable that the BabelSwitch responds to only midi information from the midi controller not program change messages from an fx processors)
- We have provided thru connection for midi systems which provide phantom power down 7 pin DIN cables.

BabelSwitch Application Notes

BabelSwitch Application Three -

Simple Midi switching

FX Switching

FX loop switching

At this stage we now can from a single patch on a pedalboard recall amp status and FX processor programs. The BabelSwitch allows us to switch FX in and out of an amplifiers FX loop, giving us midi muting of an FX signal. The block diagram below demonstrates this set up.

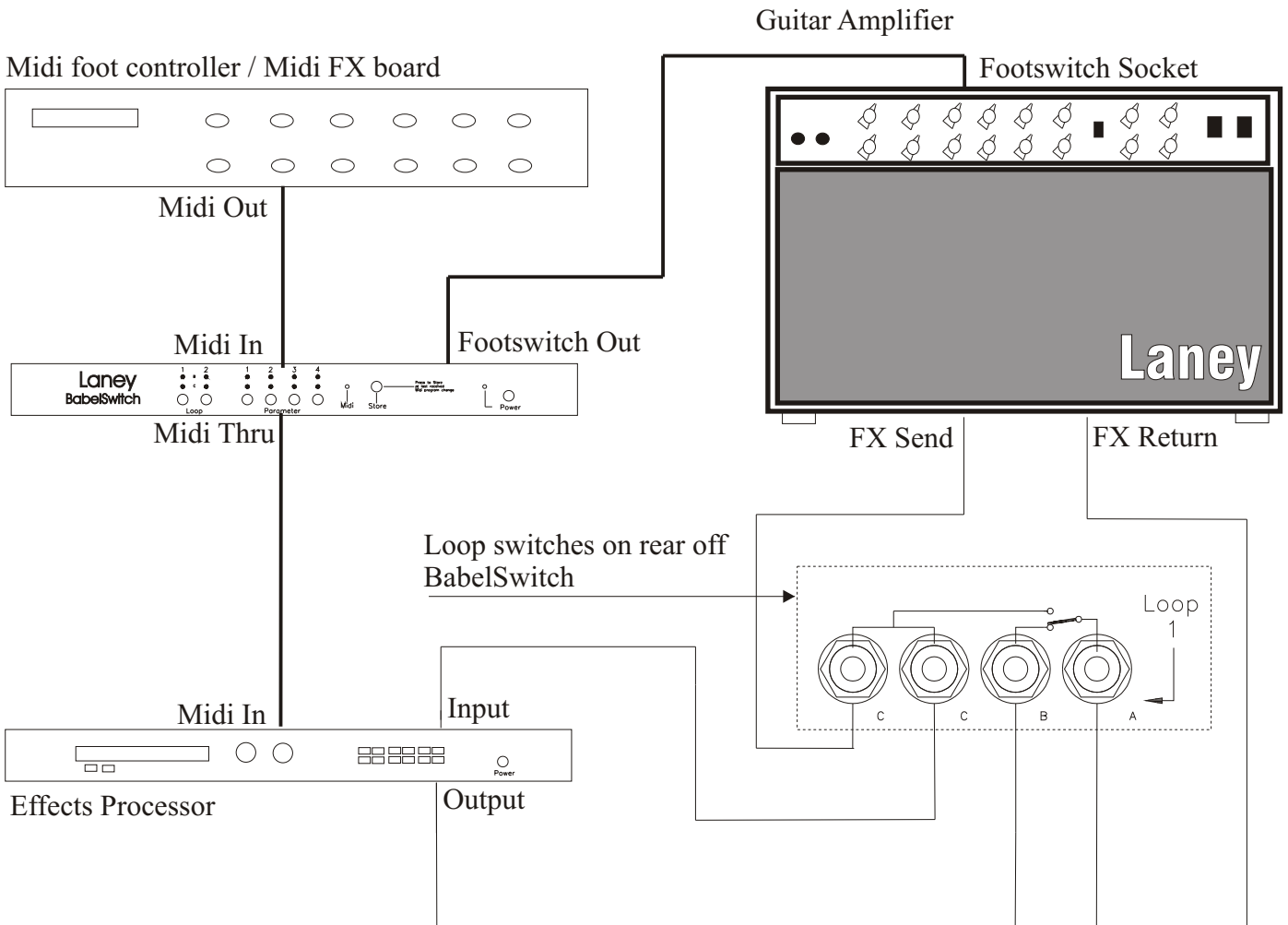

With the Jack socket switching arranged as above, the Jack socket A switches between the 'dry' signal from the amplifier or the wet signal from the Fx processor.

BabelSwitch Application Notes

BabelSwitch Application Three - Simple Midi switching Midi Controlled Boost

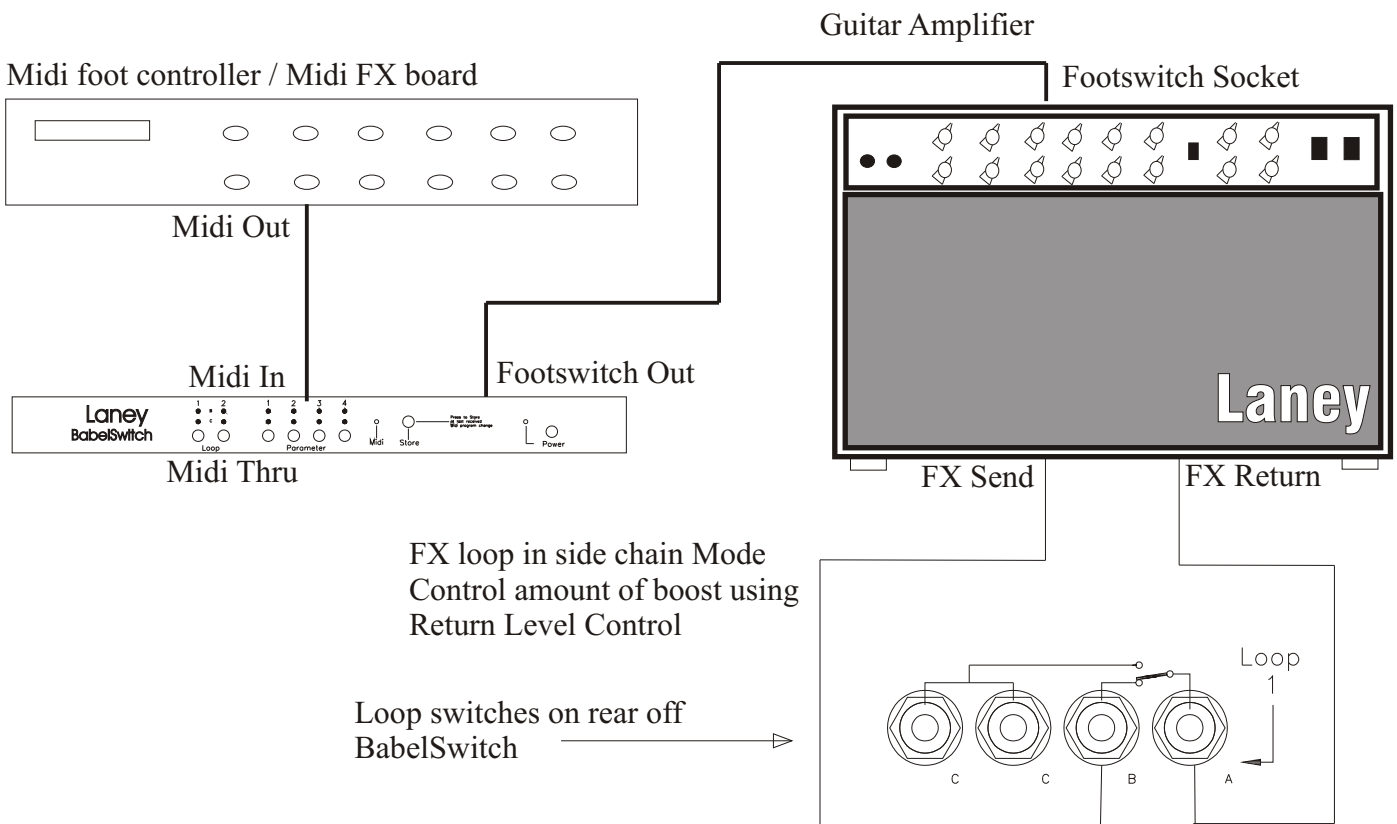

The switching loops on the rear of the BabelSwitch also allow us to perform a midi controlled boost. If you use the BabelSwitch to switch signal to the FX return sockets and the FX loop is in side chain mode, a midi controlled boost is performed. The effects return level control then determines the amount of level boost. This would be useful when switching from a rhythm sound to a lead sound.

So on an amp such as the VC50 the following combinations would be available on channel A.

- Channel A or
- Channel A + Midi Boost
- Channel A + Drive or
- Channel A + Drive + Midi Boost

So on a VC50 amplifier a total number of 8 sounds would be available for recall via midi (not inc Reverb)

Similar combinations would available for channel B. This type of switching gives a greater number of sounds available for recall by remote control.

BabelSwitch Application Notes

BabelSwitch Application Four :- Signal Switching in Multiple Amp Setups

There are instances where you might need to switch Preamp level/Guitar signal between different amps in a multi-amp setup.

- This could be to use
1. Amp A OR Amp B
 2. Amp A OR Amp A + AmpB

The diagram below demonstrates the BabelSwitch used for preamp switching
These give a starting point for creating your custom multiple amp set up
Should you experience hum problems in your set up see Appendix 1 for hints on reducing/stopping it.

Amp A or Amp B Switching

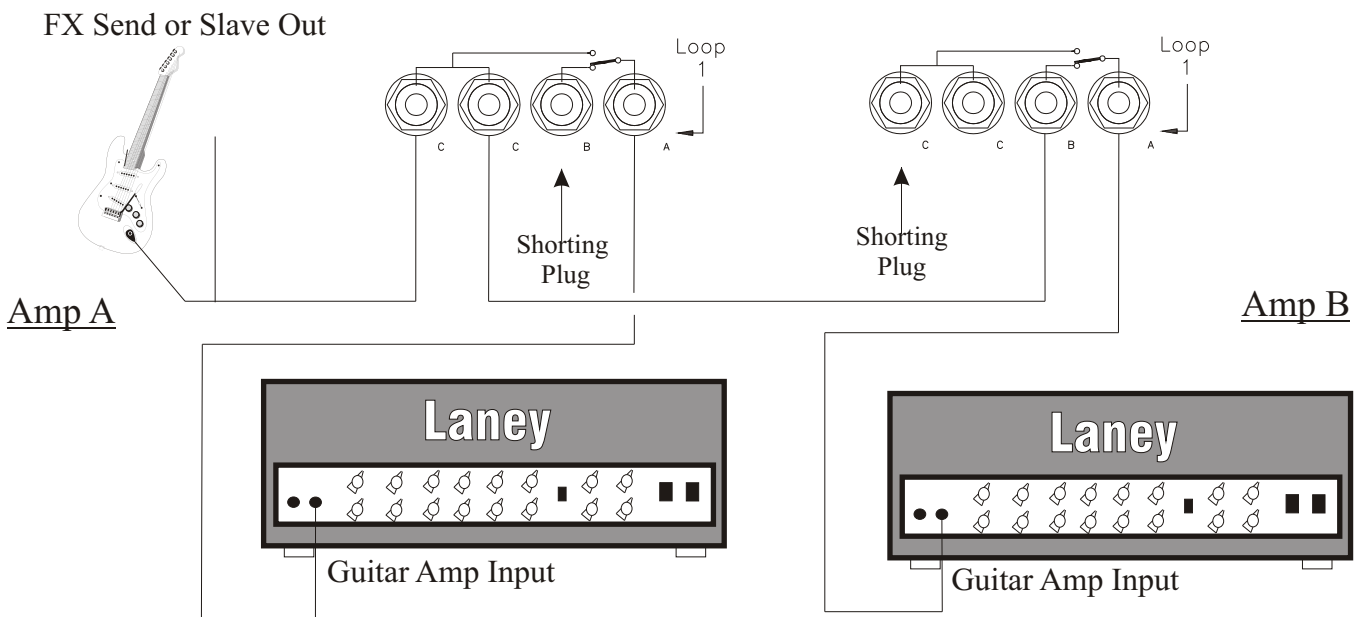

Shorting Plug - Jack plug with Tip and shield shorted together this keeps the unused amp quiet when not in use

Amp A or Amp A + Amp B Switching

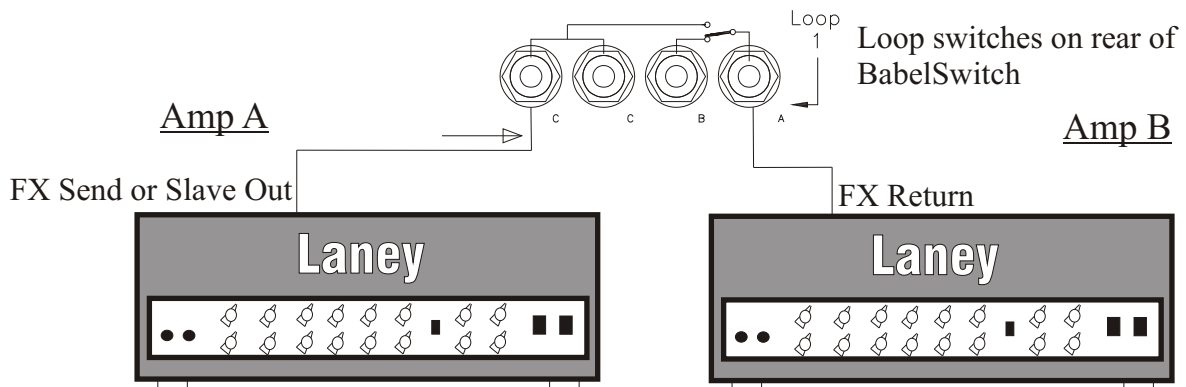

BabelSwitch Application Notes

BabelSwitch Application Five :- Bringing it together

Having now explored some of the possibilities available to the user brought by the BabelSwitch it is now time to combine them into a suggested set up. The following setup consists of

- 1) 2 FX processors
- 2) 1 Babel Switch
- 3) Guitar Amp eg VC50
- 4) Midi Controller

It demonstrates the ability to switch via midi the a VC50 and switch various FX in and out off the FX loops
If you added another BabelSwitch you could wire one of the switching loops to change over between guitars
- now you can store which guitar you want to use with each patch

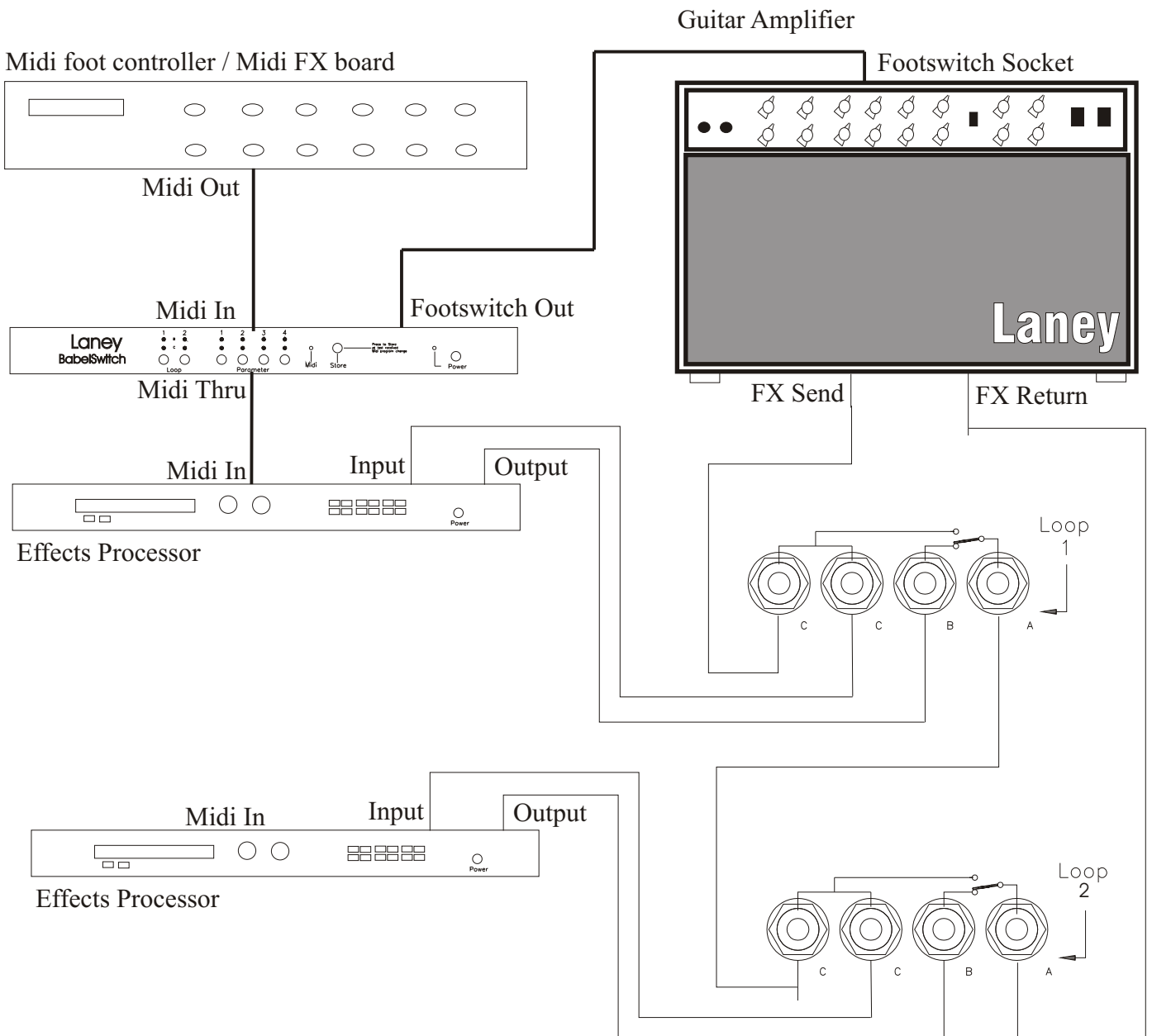

BabelSwitch Technical Specification

The BabelSwitch switch outputs are all controlled via relays and are thus electrically isolated from the BabelSwitch internal circuitry

.The switching is thus provided to grounds supplied via the footswitch sockets (5 pin Din or stereo Jacks). This also applies to the switching loops thus preventing any hum problems.see notes below

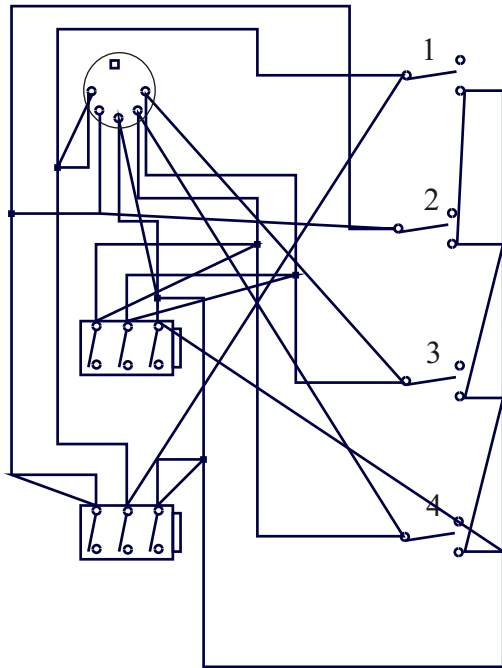

Left is shown a diagram showing the circuitry within the Babel switch. The switches shown are contacts on a relay which is under the control of a microprocessor.

The switch contacts rated at 1A so are not suitable for the switching of power amp/ loudspeaker level signals

As the switches all connect to common point supplied by the user it opens up other switching applications

BabelSwitch - Multiamp setup notes

Even with the switching isolation provided by the BabelSwitch hum problems may still be a problem in multiamp setups. Hum is caused by differences in ground between pieces of equipment

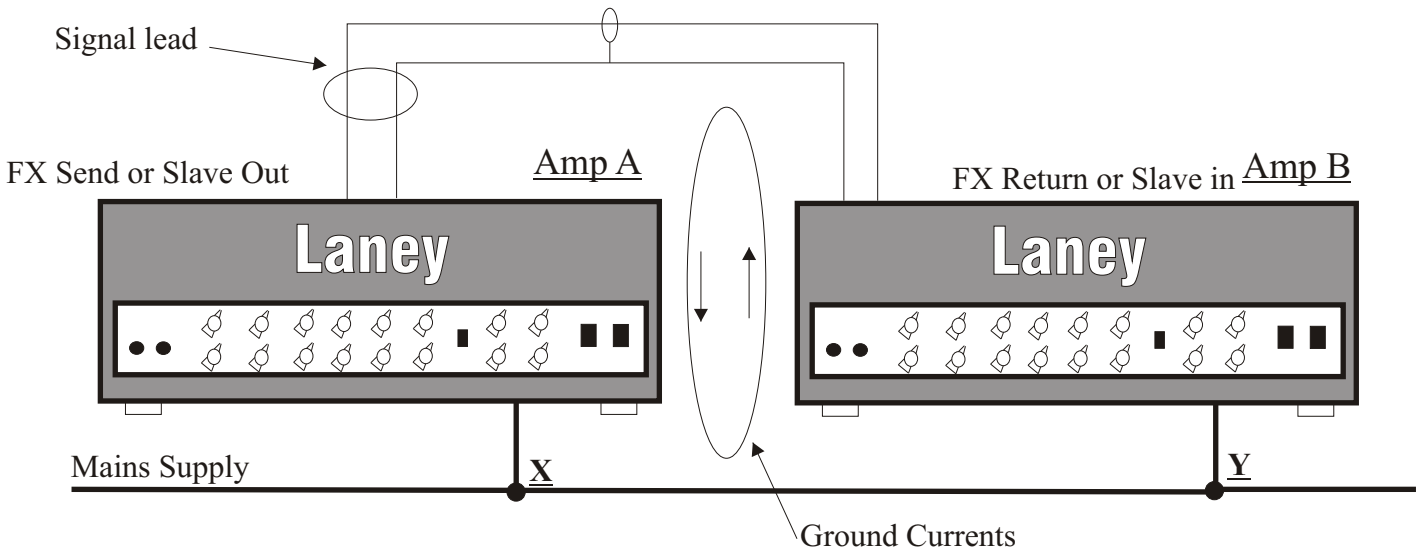

BabelSwitch - Multiamp setup notes

Overleaf is shown a diagram to demonstrate a Hum problem. In the set up shown there is difference in mains ground supplied to the 2 amplifiers

This difference in ground potential causes a small current to flow in the signal ground line between the 2 amplifiers. As amplifier B amplifies the signal from A it also amplifies the ground difference between X and Y and ground currents flowing because of this difference. This results in a hum problem

To stop the hum you must stop the ground currents flowing between A and B.

You can do this as follows

1. Fit a resistor in the ground line of the signal cable between Amp A and Amp B.

This will reduce the current flow. Try a 10R

2. Fit a 10uF capacitor in the ground line of the signal cable between Amp A and Amp B.

This will stop any current flow.

Never Remove the Mains Ground as this can cause a serious risk of Electric Shock

BabelSwitch Glossary

BabelSwitch - see fish

FX loop - an input and output point allowing effects such as Reverbs, compressors and flangers to be inserted into a signal path.

Fish - See BabelSwitch

FS1 - Footswitch with 1 switch via a mono jack

FS2 - Footswitch with 2 switches via a stereo jack

FS4 - Footswitch with 4 switches via a 5 pin Din plug
Switches Drive A, Drive B, Reverb and Channel

FS5 - Footswitch with 4 switches via a 5 pin Din plug
Switches graphic, channel, preshape, compressor

MIDI - Musical Instrument Digital Interface, a system which allows a musician's toys to communicate with each other. Eg synthesizer's, expanders, computers, FX processors, BabelSwitches

MIDI Channel - Midi devices can respond on any 1 of, or all 16 midi channels.

If a device responds to midi messages on all 16 channels it is said to be in OMNI mode

MIDI In - Socket on a midi device where midi data is received

MIDI Out - Socket on a midi device where it can send out midi data

MIDI Thru - socket on a midi device where the Midi In signal leaves unchanged to go to the next device

MIDI Controller - device, usually at the start of a midi chain, which generates midi data to control other devices.

Omni mode - a midi device is said to be omni mode when it responds to midi data on all midi channels

Patch - block memory within a midi controller/Fx unit with all the information for a required sound.

Phantom Power - usually refers to a remote power supply. eg some pedalboards can be remotely powered by dedicated FX units, or mixers often provide phantom power for condenser microphones via the mic input socket. The BabelSwitch provides a thru connection for phantom power via the MIDI In and Thru sockets.

Preset - memory within a midi controller/Fx unit with all the information for a required sound.

Program Change - a midi message which is generated when a program or patch is changed.

BabelSwitch Trouble Shooting

The BabelSwitch is a relatively simple midi device thus most problems will be incorrect wiring of midi signals or loop socket. So before proceeding further it is worth checking the connections in your setup.

Midi led does not flash	The midi led indicates the BabelSwitch is receiving midi data via the 'Midi In' socket. Check that the Midi Out of your controller is connected to the Midi In of your BabelSwitch
Midi led flashes but BabelSwitch does Nothing	The BabelSwitch only responds to midi messages if 1)Its a 'Program Change' instruction 2)The BabelSwitch is set to receive on the same channel the instruction is transmitted on ,or all channels if the BabelSwitch is set to Omni mode Also if the new setting retrieved by midi is the same as the old one nothing will appear to happen.
BabelSwitch is set to receive on one channel but does not	Channel selection sometimes appears to the user as either 1 - 16 or 0 - 15.This means that a 1 channel offset can occur between different devices. The BabelSwitch allows the user to select between 0-15 . Eg midi channel 1 - 0000 .
Store button does not work.	The Store button needs to be held down for 1 second ,the led's then flash all green /all red to confirm a store has successfully taken place
Parameter Switches do not effect my amplifier	Check the correct switch outputs from the BabelSwitch are connected to your amplifier. (Not a midi port for instance) Check the switches on your amplifier are in state which allows remote control.
I want to use a BabelSwitch instead of a FS2 but only 1 thing switches	Check the switches on your amplifier are in state which allows remote control. Check the switch output to you amplifier head is a stereo jack lead.

BabelSwitch Midi Implementation

See
C:\RJF_WORK\MIDI.DOC

#